



GREEN LAKE COUNTY

571 County Road A, Green Lake, WI 54941

Original Post Date: 05/31/2019

Amended* Post Date:

The following documents are included in the packet for the Property and Insurance on June 4, 2019:

- 1) Agenda
- 2) Minutes from 05/07/19
- 3) Potter Lawson Entrance Information
- 4) Maintenance Monthly Report



**GREEN LAKE COUNTY
OFFICE OF THE COUNTY CLERK**

*Elizabeth Otto
County Clerk*

*Office: 920-294-4005
FAX: 920-294-4009*

***Property & Insurance Committee
Meeting Notice***

Date: June 4, 2019 Time: 5:00 PM

Location: Government Center, County Board Room, 571 County Road A, Green Lake WI

AGENDA

**Committee
Members**

*Vicki Bernhagen, Chair
Patti Garro, Vice-Chair
David Abendroth
Richard Trochinski
Keith Hess*

Elizabeth Otto, Secretary

1. Call to Order
2. Certification of Open Meeting Law
3. Pledge of Allegiance
4. Minutes: 05/07/19
5. Correspondence
6. Public Comments (3 min limit)
7. Use of County Property
 - RADAR Team Request
8. Security Systems Update
9. Maintenance Report
 - Monthly Activities
10. Committee Discussion
 - Future Meeting Dates: Regular Meeting July 2, 2019 -5:00 PM
 - Future Agenda items for action & discussion
11. Adjourn

Kindly arrange to be present, if unable to do so, please notify our office. Sincerely, Elizabeth Otto, County Clerk

Please note: Meeting area is accessible to the physically disabled. Anyone planning to attend who needs visual or audio assistance, should contact the County Clerk's Office, 294-4005, not later than 3 days before date of the meeting.

PROPERTY AND INSURANCE COMMITTEE

May 7, 2019

The meeting of the Property and Insurance Committee was called to order by Chair Vicki Bernhagen on Tuesday, May 7, 2019 at 5:00 PM in the Green Lake County Board Room, Green Lake County Government Center, 571 County Road A, Green Lake, WI. The requirements of the open meeting law were certified as being met. The pledge of allegiance was recited.

Present: Vicki Bernhagen
Richard Trochinski
David Abendroth

Absent: Keith Hess
Patti Garro

Other County employees present:

Liz Otto, County Clerk
Scott Weir, Maintenance Supervisor
Cathy Schmit, Cty Administrator
Dawn Klockow, Corporation Counsel

Barry Mashuda, Hwy Commissioner
Harley Reabe, Cty Board Chair
Sheriff Mark Podoll

MINUTES

Motion/second (Abendroth/Trochinski) to approve the minutes of April 2, 2019 with no additions or corrections. All ayes. Motion carried.

CORRESPONDENCE

County Clerk Liz Otto read an email from Naomi Pulvermacher requesting approval for the RADAR (Regional Area Dive and Rescue) Team to hold a fundraiser at Dodge Memorial park and sell food this summer. They have no definite date in mind as of yet. The committee advised Corporation Counsel Dawn Klockow to look into the legal aspect of selling food on county property. This will be put on the June agenda for discussion and possible action.

PUBLIC COMMENTS – none

USE OF COUNTY PROPERTY - none

BUDGET ADJUSTMENTS/LINE ITEM TRANSFER - none

PURCHASE REQUESTS

- Bulldozer – Highway

Highway Commissioner Barry Mashuda stated that the Highway department sold a bulldozer in 2015 because it was too big for their needs and was never replaced. They have been renting one on an as needed basis since then and losing possible revenue. County Administrator Cathy Schmit explained the depreciation/revenue ratio when renting vs. owning.

Motion/second (Abendroth/Trochinski) to approve the purchase of a 2018 Cat D4K2 Dozer for \$111,700.00. Motion carried.

- I-phone request – Coroner

A request from Coroner John Willett was included in the packet to replace the current flip phones for Deputy Coroners with iphones due to poor picture quality and age.

Motion/second (Trochinski/Abendroth) to approve the purchase of 2 new iphones for Deputy Coroners. All ayes. Motion carried.

UPDATE ON HEALTH INSURANCE FOR 2020

County Clerk Liz Otto and County Administrator Cathy Schmit updated the committee on the process involved to check into health insurance options for 2020. Discussion held.

SECURITY SYSTEMS UPDATE

County Administrator Cathy Schmit stated that the final design plans from Potter Lawson are complete and have been submitted to the state for approval. IMEG is working on the electronic portion of the security system upgrade and will be doing the RFP as well.

MAINTENANCE REPORT

- Monthly Activities - The report was reviewed. Maintenance Supervisor Scott Weir gave an update. Discussion held.

COMMITTEE DISCUSSION

Future Meeting Date: Next meeting date: June 4, 2019 at 5:00 PM.

Future Agenda items for action & discussion: RADAR Team request

ADJOURNMENT

Chair Bernhagen adjourned the meeting at 5:17 PM.

Submitted by,

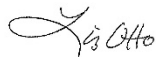

Liz Otto
County Clerk

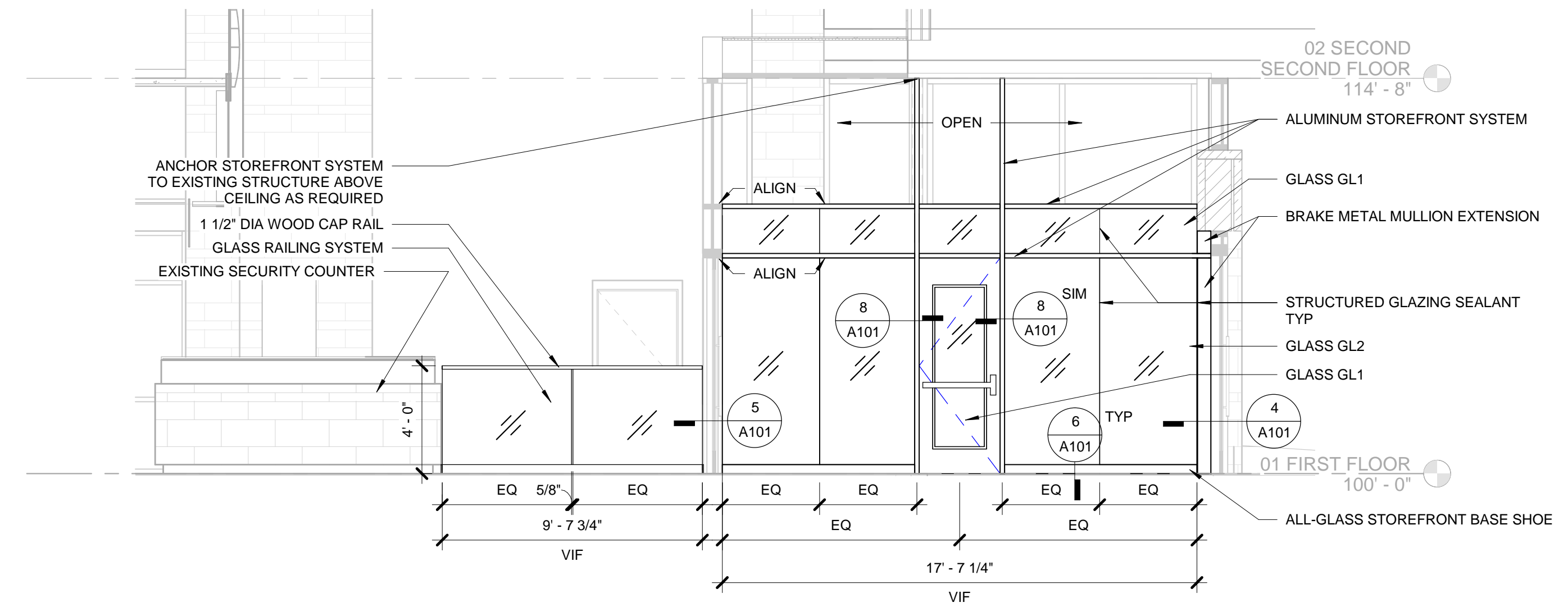

3 ELEVATION
1/4" = 1'-0"

HARDWARE GROUP NO. 1000J			
DESCRIPTION	CATALOG NUMBR	FINISH	MANUFACTURER
CONTINUOUS HINGE	112XY	628	IVE
PANIC HARDWARE	CD-99-AN-OP-110MD	626	VON
RIM CYLINDER	20-057 VERIFY KEYWAY TO MATCH PRIOR TO ORDERING	626	SCH
MORTISE CYLINDER	20-061 NUM X011-948 36-083 VERIFY KEYWAY TO MATCH PRIOR TO ORDERING	626	SCH
ELECTRIC STRIKE	6300 FSE 12/24 VAC/VDC	630	VON
DOOR PULL	MATCH EXISTING (FIELD VERIFY MFG, SIZE AND STYLE)	630	UNK
OH STOP	100SE	630	GLY
SURF. AUTO OPERATOR	4642 WMS 120V AC	689	LCN
ACTUATOR, JAMB MOUNT	8310-818	630	LCN
BOLLARD POST FOR ACTUATOR BUTTON AND CARD READER	#4 BRUSHED STAINLESS STEEL 2" DIAMETER PIPE BOLLARD WITH STAINLESS STEEL WELDED CLOSURE AT TOP COORDINATE W/ELECTRICAL SECURITY CONTRACTOR	630	WIK

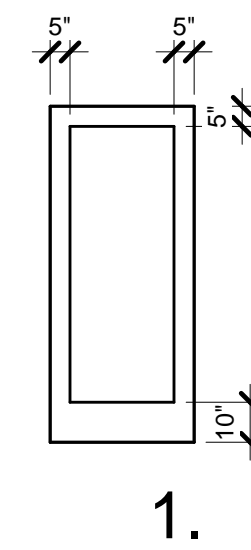

1. CREDENTIAL READER DEVICE IS TO RETRACT THE LATCHES AND SHUNT ANY ALARM ASSOCIATED WITH THE DOOR CONTACTS ALLOWING THE DOORS TO BE OPENED. MANUAL KEYED INGRESS IS ALSO AVAILABLE IMMEDIATE EGRESS IS ALWAYS AVAILABLE. TIMED LOCKING/UNLOCKING VIA THE SECURITY SYSTEM IS ALSO AVAILABLE. ITEMS TO BE PROVIDED BY THE DIVISION 28 SUPPLIER. CREDENTIAL READER DEVICE WIRING TO THE PS902 POWER SUPPLY (WHICH POWERS THE QEL ELECTRIC LATCH RETRACTION FEATURE INSIDE THE PANIC HARDWARE), THE QEL ELECTRIC LATCH RETRACTION FEATURE INSIDE THE PANIC HARDWARE ITSELF AND THE DOOR CONTACT(S).

7 DOOR ELEVATION - 1000J
1/4" = 1'-0"

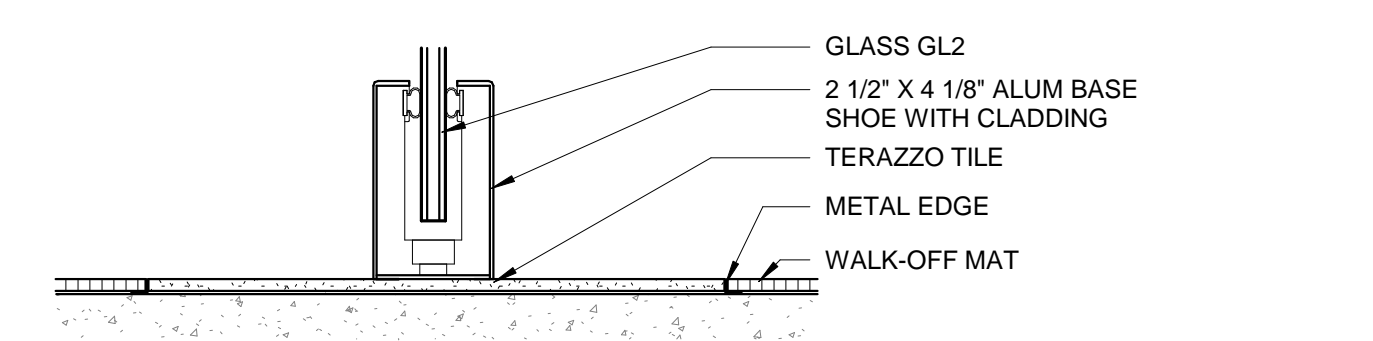

6 INTERIOR GLASS SILL
3" = 1'-0"

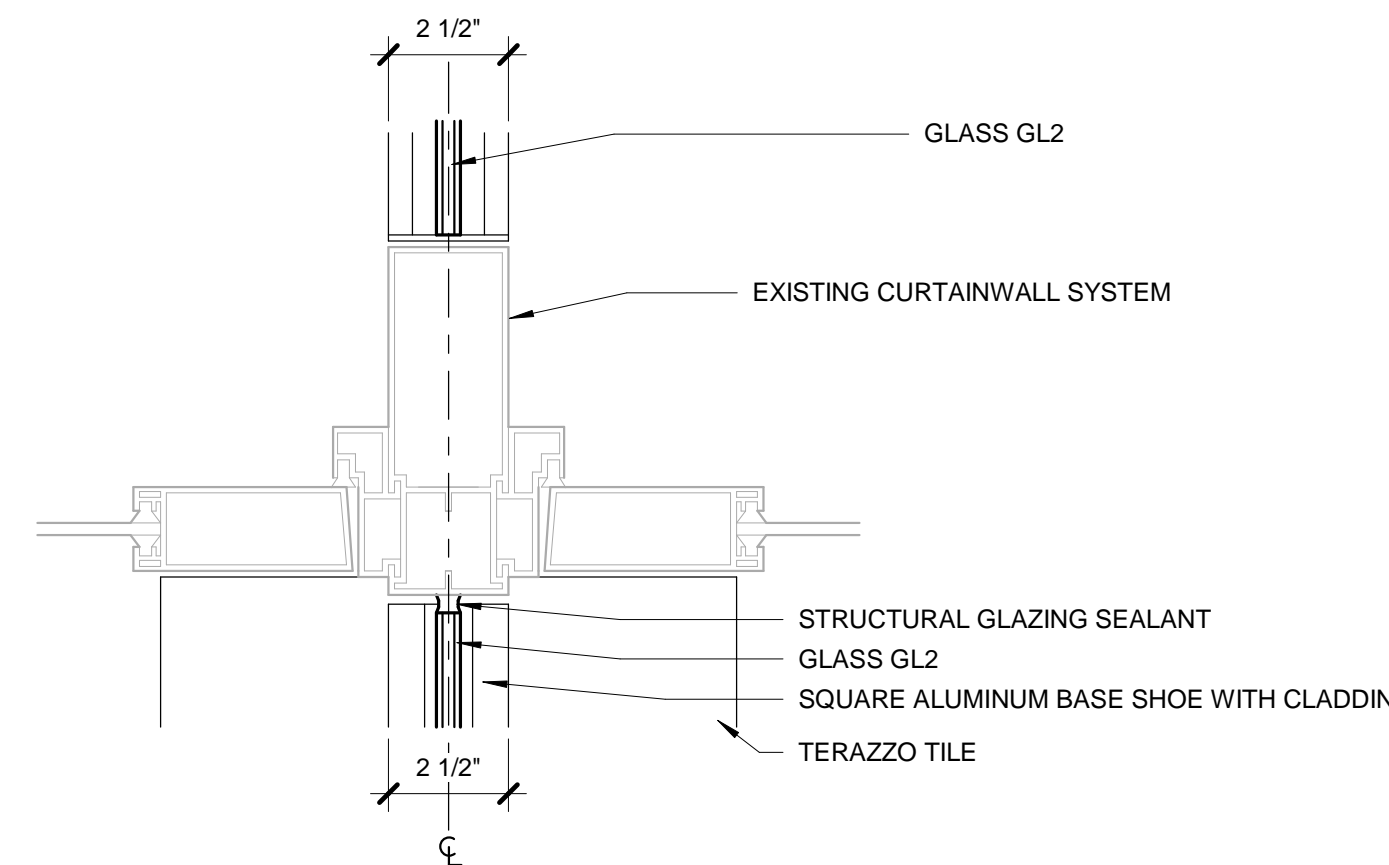

5 PLAN DETAIL
3" = 1'-0"

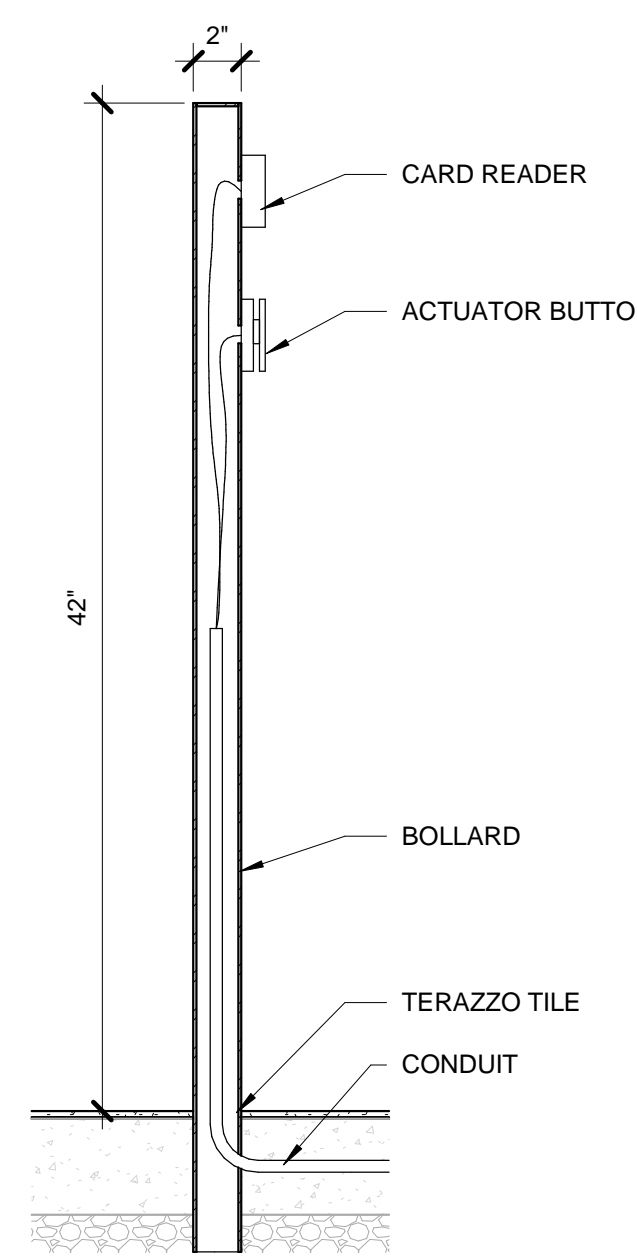

9 BOLLARD DETAIL
1 1/2" = 1'-0"

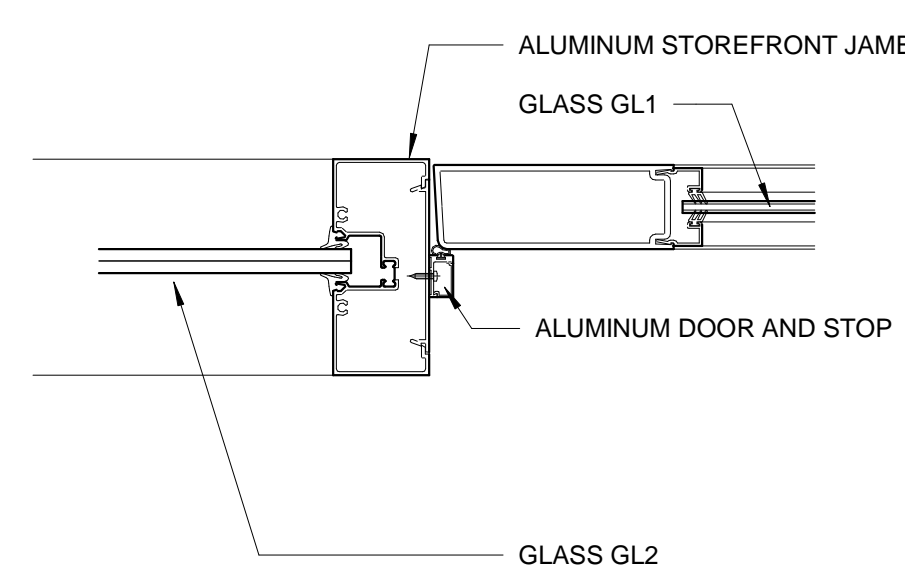

8 STOREFRONT JAMB DETAIL
3" = 1'-0"

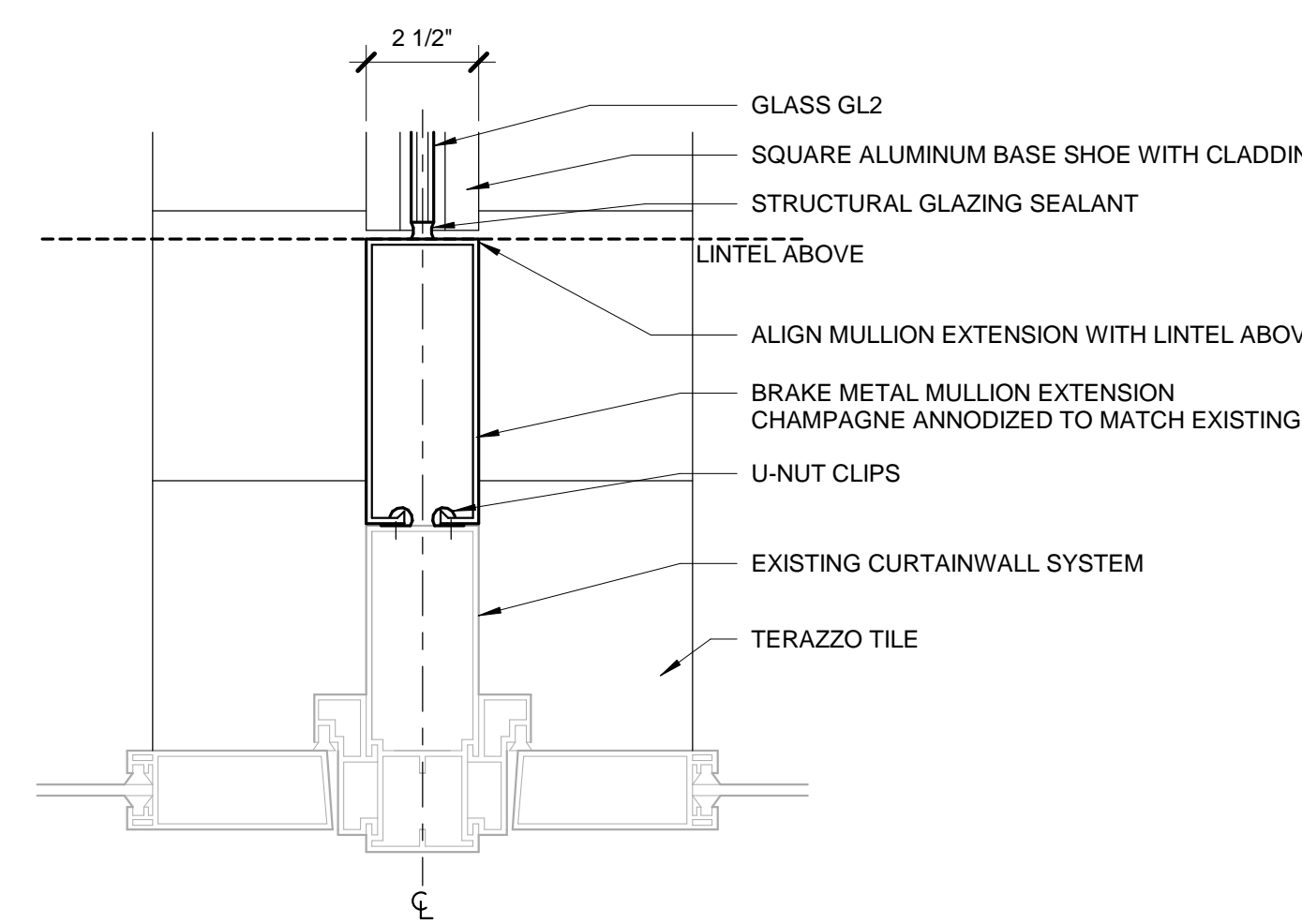

4 PLAN DETAIL
3" = 1'-0"

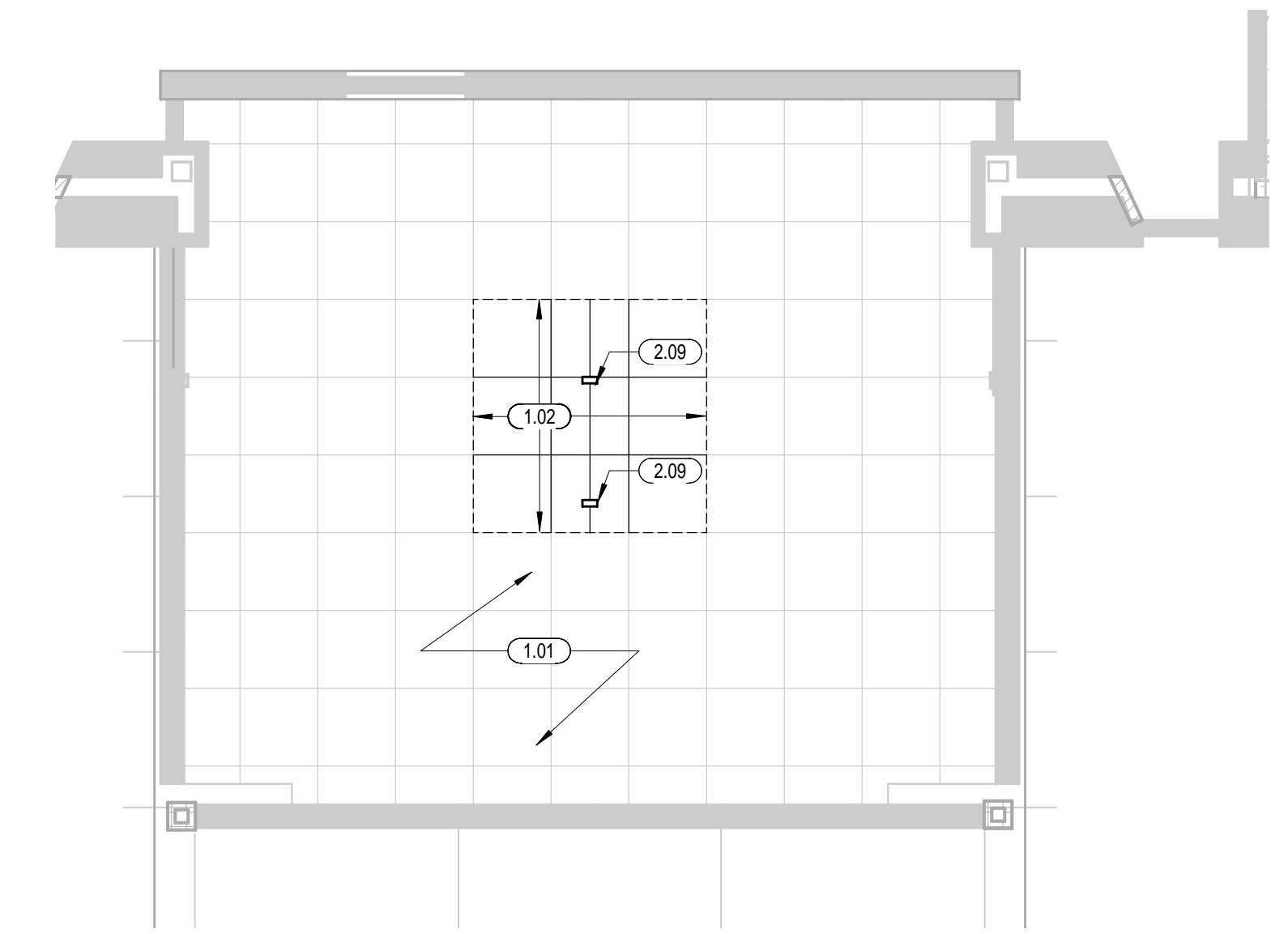

2 PARTIAL FIRST FLOOR REFLECTED CEILING PLAN - VESTIBULE 1001
1/4" = 1'-0"

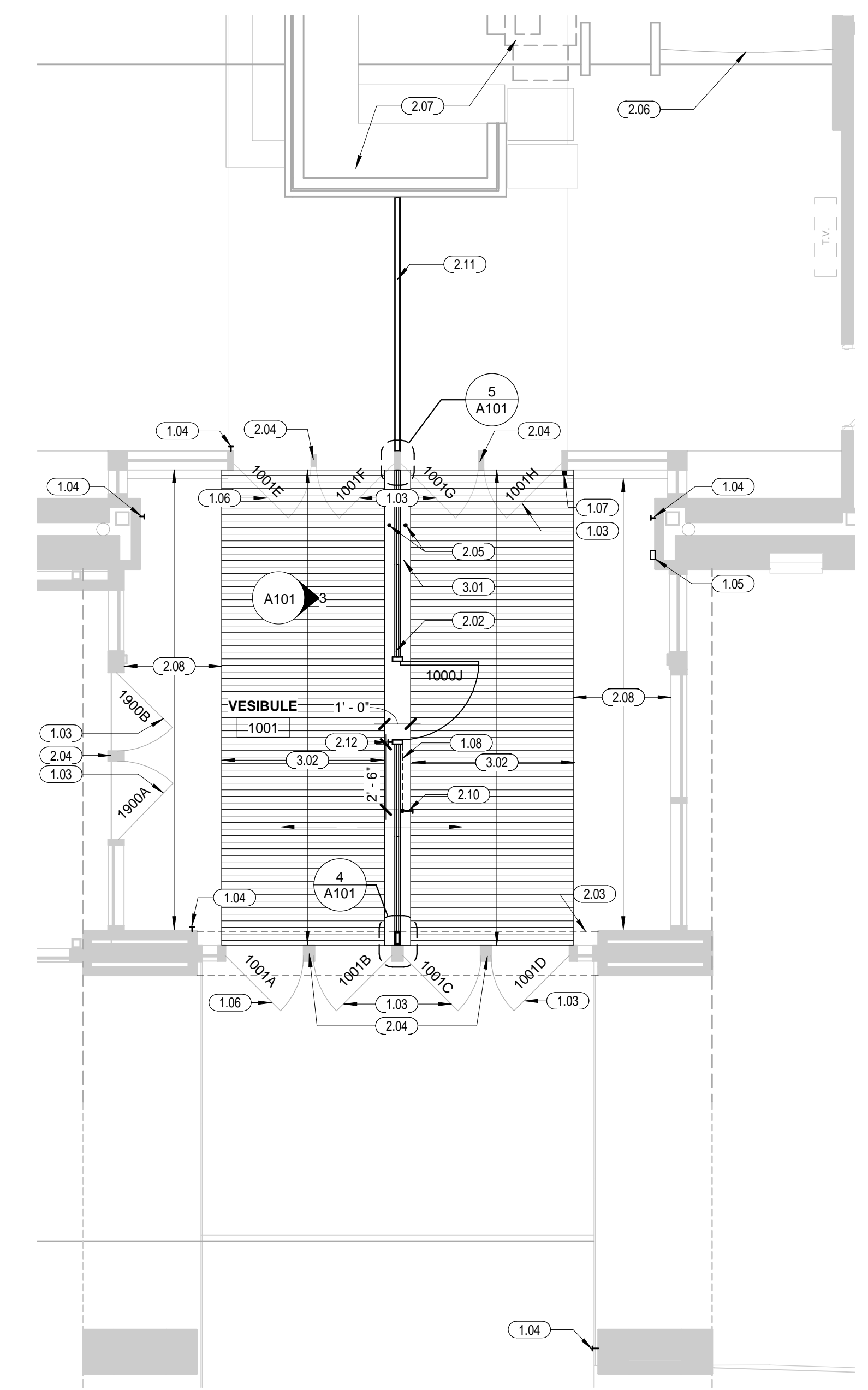

1 PARTIAL FIRST FLOOR PLAN - VESTIBULE 1001
1/4" = 1'-0"

Notes:

- ALL GLASS GL-1 UNLESS OTHERWISE NOTED.
- SPRINKLER CONTRACTOR TO VERIFY IF SPRINKLER RENOVATION IN VESTIBULE 1001 IS REQUIRED.

Keynote Legend

#	Keynote Text
1.01	EXISTING LIGHT FIXTURES AND DIFFUSERS TO REMAIN.
1.02	REMOVE AND SALVAGE EXISTING 2' X 2' CEILING TILE AS REQUIRED TO INSTALL VERTICAL STOREFRONT MEMBERS. REINSTALL CEILING TILE AND GRID AS REQUIRED.
1.03	EXISTING HARDWARE TO REMAIN.
1.04	EXISTING AUTO OPENER TO REMAIN.
1.05	EXISTING PHONE TO REMAIN.
1.06	REMOVE EXISTING DOOR PULL AND PLUG HOLES. ALL OTHER EXISTING HARDWARE TO REMAIN.
1.07	EXISTING CARD READER TO REMAIN.
1.08	CUT EXISTING CONCRETE SLAB AS REQUIRED FOR ELECTRICAL RACEWAY FROM STOREFRONT FRAMING TO POST.
2.02	NEW ALUMINUM STOREFRONT SYSTEM.
2.03	EXISTING LINTEL ABOVE.
2.04	EXISTING CURTAINWALL SYSTEM AND DOORS TO REMAIN.
2.05	NEW DOOR STOPS ANCHORED TO FLOOR.
2.06	EXISTING REMOVABLE BARRIER BELT TO REMAIN.
2.07	EXISTING SECURITY DESK AND SCREENING SYSTEM TO REMAIN.
2.08	EXISTING TERRAZZO TILE TO REMAIN.
2.09	VERTICAL STOREFRONT MEMBERS TO BE ANCHORED TO EXISTING STRUCTURE ABOVE CEILING AS REQUIRED.
2.10	NEW 2" DIAMETER PIPE BOLLARD WITH MOUNTED ACTUATOR BUTTON AND CARD READER. SEE DETAIL 9/A101.
2.11	NEW GLASS RAILING SYSTEM.
2.12	NEW AUTO OPENER ACTUATOR MOUNTED TO FRAME.
3.01	NEW TERRAZZO TILE TO MATCH EXISTING.
3.02	REMOVE EXISTING WALK OFF MAT. INSTALL NEW WALK OFF MAT. VERIFY SIZE IN FIELD.

VESTIBULE REMODEL
GREEN LAKE COUNTY

571 COUNTY HWY. 'A'
GREEN LAKE, WISCONSIN
54941

2018.05.00

Date	Issuance/Revisions	Symbol
05/15/2019	CONSTRUCTION DOCUMENTS	

**FIRST FLOOR
PLAN, ELEVATION,
& DETAILS**

A101

June 04, 2019
Property & Insurance Committee
Monthly Report
Green Lake County Maintenance Department

571 County Road A

Replaced peeling caulk around edge of dirty side of newly installed dish machine by outside vendor – Corrections
Request to lube master control door latch because of substantial friction/lubed - Corrections
Replace ballast in fixture Unit E cell #2 – Corrections
Tighten lock cylinder on plumbing chase door Unit K – Corrections
Replaced ballast and lamps above sinks Unit K – Corrections
Unplugged condensate line OAHP #3 – Corrections
Replaced removed sealant on back of sink in Rec. cell #5 – Corrections
Request to lube unit A door latch because of substantial friction/lubed - Corrections
Straighten and tighten drain pipe under sink break area – SO
Request to remove lock on patrol office locker/lost key – Drilled lock open @10:29a/05/23/19 - SO
Replaced worn doorstop Training Room entrance door left side – UWEX
Set up Training Room per request for 05/08/19 – UWEX
Replaced back up battery in fire suppression system in vault – ROD
Replacement plantings have been ordered for facility grounds
HVAC System programed for seasonal operation 05/06/13 & 05/13/19
Leveled and seeded areas where corrections garden was located
Adjusted lockset on door to breakroom – DA
Performed Scheduled Maintenance
Performed general Maintenance

Lake Steel Street

Adjusted temp in double door cooler per request – Food Pantry
Gutters cleaned storage shed
Performed Scheduled Maintenance
Performed General Maintenance

Towers

Reset throttle alarm on emergency generator controller - Princeton
Performed Scheduled Maintenance
Performed General Maintenance

Summer Maintenance LTE Conner Ritcher started 05/20/19 this is Conner's third summer- Welcome Back!

FRI

Performed Maintenance Request
Performed Maintenance Supply Request

Submitted by:

A handwritten signature in black ink, appearing to read "Scott A. Weir". The signature is written in a cursive style with a large, looping initial "S".

Scott a. Weir
Maintenance Director
Parks & Recreation Director
Green Lake County